



# ADTECH

95 Mt. Read Blvd # 149  
Rochester, New York 14611 USA  
Phone: 1.585.698.1845  
Fax: 1.585.697.0445

www.adtech-inst.com

## ANALOG LINEARIZER MODULE MODEL NO. ALM 00

THE ADTECH MODEL ALM 00 ANALOG LINEARIZER MODULE OFFERS AN ACCURATE AND ECONOMICAL MEANS OF CONVERTING WHOLE OR FRACTIONAL POWER FUNCTIONS INTO LINEAR OUTPUTS SUCH AS LINEAR FLOW OUTPUTS FROM FLUMES AND WEIRS.

THE STANDARD MODEL HANDLES MONOTONIC FUNCTIONS SUCH AS ROOT EXTRACTION AND POWER FUNCTIONS. THE POWER EXPONENT IS ADJUSTABLE BY A SINGLE MULTITURN POTENTIOMETER AND IS NON-INTERACTIVE WITH THE ZERO OR SPAN CALIBRATION POTENTIOMETERS. THE VALUE OF THE POWER EXPONENT IS LIMITED FROM 0.2 TO 5.

OPTION O 43 PROVIDES LOGARITHMIC FUNCTIONS ON A CONTINUOUS CALCULATION METHOD, AND THE OUTPUT MAY BE THE LOG OF INPUT OR ANTILOG OF INPUT.

THE 10-SEGMENT BREAKPOINT LINEARIZER, OPTION O 42, PROVIDES EASY CALIBRATION WITH EACH SEGMENT ALLOWING AN INCREASE OR DECREASE OF SLOPE WITH THE CENTER POSITION OF THE POTENTIOMETER PROVIDING A GAIN OF ONE. ALSO AVAILABLE IS COMBINED ROOT EXTRACTION WITH BREAKPOINT LINEARIZATION, WHICH PROVIDES BETTER CURVE LINEARIZATION.

ZERO, SPAN AND OTHER CONTROLS ARE PROVIDED BY INFINITE RESOLUTION POTENTIOMETERS. RECALIBRATION TO OTHER RANGES WITHIN THE SPECIFICATIONS FROM A CURRENT OR VOLTAGE SOURCE TO STANDARD PROCESS SIGNALS SUCH AS 4-20 MA DC, 1-5 VDC, OR ZERO-BASED OUTPUT IS VERY CONVENIENT.

THE ALM 00 EMPLOYS THE LATEST DESIGN AND COMPONENTS UTILIZING PROVEN TECHNIQUES FOR THE UTMOST IN RELIABILITY, ACCURACY AND SERVICEABILITY.

THE ALM 00 PROVIDES STANDARD PROCESS CURRENT OR VOLTAGE SIGNALS ON THE OUTPUT WITH A MAXIMUM OF 10 mV P/P OUTPUT RIPPLE. IT OFFERS A CONVENIENT WAY OF INTERFACING NONLINEAR SIGNALS TO A COMPUTER SYSTEM OR OTHER PROCESS INSTRUMENTATION FOR IMPROVED RESOLUTION.

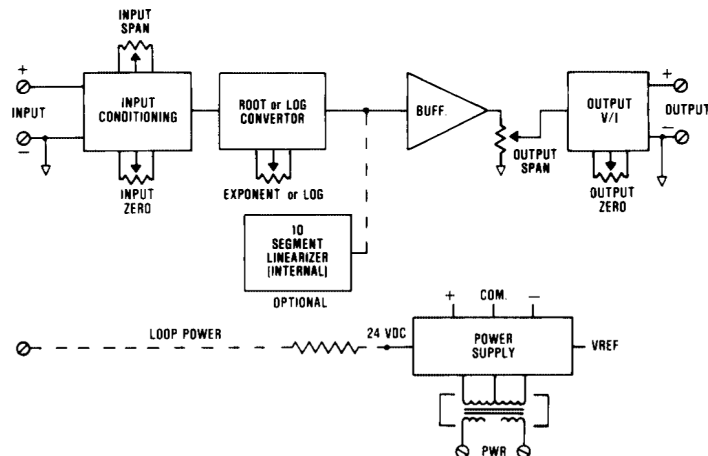

### TYPICAL APPLICATIONS

- FLUME AND WEIR-FLOW LINEARIZATION
- LOGARITHMIC CONVERSIONS
- ANALYZER LINEARIZATION
- PH OR ION CONCENTRATION
- CYLINDRICAL OR SPHERICAL TANK VOLUME COMPUTATION
- DENSITY OR TURBIDITY LINEARIZATION
- RADIATION PYROMETER LINEARIZATION
- SIGNAL CHARACTERIZATION

### FEATURES

- SOLVES:  $x^{3/2}$ ,  $x^{5/2}$ , OR  $x^n$  WHOLE OR FRACTIONAL POWERS
- WHOLE OR FRACTIONAL POWERS: 0.2 TO 5
- LOG OR ANTILOG CONVERSION- OPTIONAL
- 10-SEGMENT LINEARIZATION-OPTIONAL
- DC CURRENT INPUTS: 4-20 MA, ETC.
- DC VOLTAGE INPUTS: 1-5 VDC, ETC.
- LOW IMPEDANCE CURRENT INPUTS: 1/10 STANDARD-OPTIONAL
- REPEATABILITY:  $\pm 0.02\%$  OF SPAN
- HIGH ACCURACY:  $\pm 0.1\%$  OF SPAN



# CONNECTIONS / DIMENSIONS

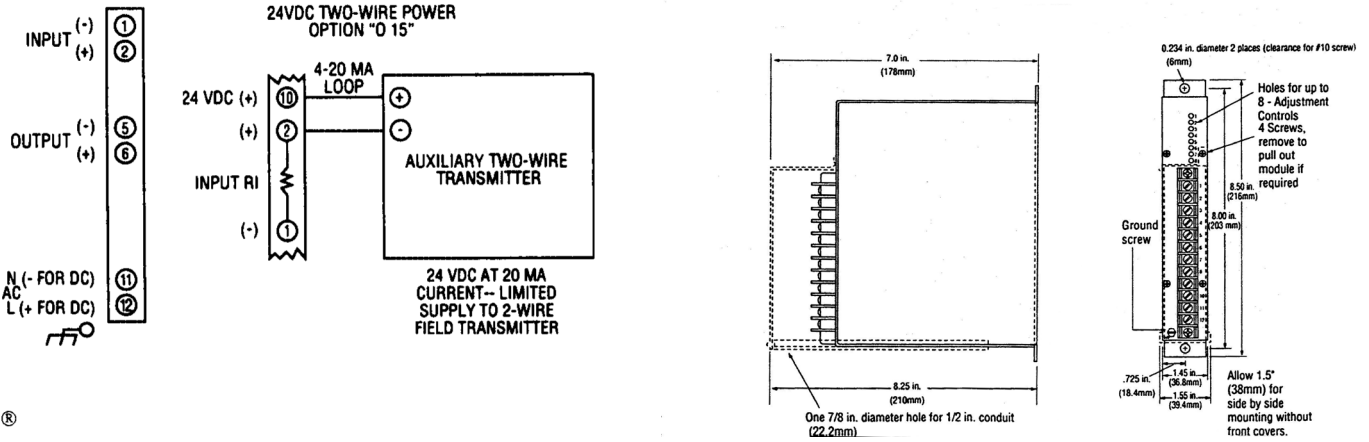

## INPUT/OUTPUT

**INPUT SIGNALS**  
 4-20 mA DC (Z IN 250 OHMS)  
 10-50 mA DC (Z IN 100 OHMS)  
 0-1 mA DC (Z IN 5K OHMS)  
 0-10 mA DC (Z IN 500 OHMS)  
 1-5 VDC (Z IN 10 MEGOHMS)  
 0-5 VDC (Z IN 10 MEGOHMS)  
 0-10 VDC (Z IN 1 MEGOHM)  
 OTHER ZERO-BASED CURRENT AND VOLTAGES ARE AVAILABLE.

OUTPUT SIGNALS / OUTPUT DRIVE (RL)		
SIGNAL	AC POWER (RL)	DC POWER (RL)
4-20 mA DC	0-1,000 OHMS MAX.	0-900 OHMS MAX.
10-50 mA DC	0-400 OHMS MAX.	0-350 OHMS MAX.
0-1 mA DC	0-20,000 OHMS MAX.	0-18,000 OHMS MAX.
1-5 VDC	100K OHMS MIN.	100K OHMS MIN.
0-10 VDC	200K OHMS MIN.	200K OHMS MIN.

## PERFORMANCE

**CALIBRATED ACCURACY:** ±0.1%  
**LINEARITY:** ±0.1% MAX., ±0.04% TYPICAL  
**REPEATABILITY:** ±0.05% MAXIMUM  
**TEMPERATURE STABILITY:** ±0.01%/°F., ±0.004%/°F TYPICAL  
**LOAD EFFECT:** ±0.01% ZERO TO FULL LOAD  
**OUTPUT RIPPLE:** 10 mV P/P MAXIMUM  
**RESPONSE TIME:** 150 MILLISECONDS  
 \*WHEN SUPPLIED AS A ROOT OR EXPONENTIAL FUNCTION, RESPONSE TIME IS FOR 25% OF RANGE OR GREATER  
**NOTE:** ALL ACCURACIES ARE GIVEN AS A PERCENTAGE OF SPAN

**TEMPERATURE RANGE:** 0° TO 140 °F (-18° TO 60 °C)  
**OPERATING:** -40° TO 185 °F (-40° TO 85 °C) **STORAGE**  
**POWER SUPPLY EFFECT:** ±0.05% FOR A ±10% POWER VARIATION

## POWER

115 VAC: 50/60 HZ, 0.7 PF (STANDARD)	48 VDC: ISOLATED (OPTION P3)
12 VDC: ISOLATED (OPTION P8)	125 VDC: ISOLATED (105-140 VDC) (OPTION P4)
24 VDC: NON-ISOLATED (OPTION P1)	230 VAC: 50/60 HZ, 0.7 PF (OPTION P5)
24 VDC: ISOLATED (OPTION P2)	

NOTE: ALL UNITS 3 WATTS MAXIMUM, AND A ±10% POWER VARIATION UNLESS NOTED.

## MECHANICAL

**ELECTRICAL CLASSIFICATION:** GENERAL PURPOSE  
**CONNECTION:** BARRIER TERMINAL STRIP (3/8" SPACING, NO. 6 SCREWS)  
**CONTROLS:** MULTITURN ZERO AND SPAN CONTROLS  
**MOUNTING:** SURFACE MOUNTING STANDARD. SEE HOUSINGS SECTION FOR OPTIONS.  
**WEIGHT:** NET UNIT: 2.6 POUNDS (1.18 KILOGRAMS); SHIPPING: 3.0 POUNDS (1.6 KILOGRAMS)

## OPTIONS

OPTION NUMBER	DESCRIPTION
I 14	VOLTAGE INPUTS TO 200 VDC, 1 MEGOHM MIN. IMPEDANCE; CURRENT INPUTS OF 100 mA MAX.
I 18	LOW IMPEDANCE DC CURRENT INPUTS (1/10 OF STANDARD Z)
O 10 & O 11	BIPOLAR OUTPUTS
O 15	TWO-WIRE TRANSMITTER EXCITATION
O 42	10-SEGMENT LINEARIZER
O 43	LOGARITHMIC LINEARIZER
H 10	THIN-LINE CONDUIT MOUNTING PLATE AND TERMINAL COVER
H 13B, H 14B, H 15B	NEMA 4.7, AND 12 ENCLOSURES
H 16	PFA 12 HIGH-DENSITY, PLUG-IN ENCLOSURES

### Ordering Information

- Model number
- Input signals
- Number of inputs
- Equation and scaling factors
- Output signal
- Prime power with option no.
- Input/output options
- Housing and miscellaneous options

Please refer to the Housing and/or Option Section for more specific and detailed information.