



# ADTECH

95 Mt. Read Blvd # 149  
Rochester, New York 14611 USA  
Phone: 1.585.698.1845  
Fax: 1.585.697.0445

www.adtech-inst.com

## ISOLATED SIGNAL CONVERTER AC POWERED MODEL NO. SCT 502

THE ADTECH MODEL SCT 502 AC POWERED ISOLATED SIGNAL CONVERTER PROVIDES A USER CONFIGURABLE SOLUTION FOR GROUND LOOPS AND PROBLEMS ENCOUNTERED IN CONNECTING TOGETHER RECORDERS, PROCESS CONTROL SYSTEMS, COMPUTERS, DCS AND PLC SYSTEMS. THE SCT 502 BREAKS THE GALVANIC PATH BETWEEN THE TRANSMITTED SIGNAL AND THE OUTPUT RECEIVING DEVICE INSURING RELIABLE AND ACCURATE SIGNAL TRANSFER.

IT IS HIGHLY USEFUL FOR APPLICATIONS THAT REQUIRE SIGNAL ISOLATION TO ELIMINATE GROUND LOOPS, INSTRUMENTATION LEVEL SHIFTS, OR THE CONDITIONING OF A PROCESS SIGNAL RIDING HIGH OVER COMMON MODE AC OR DC VOLTAGES. ANOTHER COMMON APPLICATION IS TO PROVIDE ADDITIONAL AMPLIFICATION OR DRIVE TO A PROCESS SIGNAL LOOP.

AN IMPORTANT FEATURE PROVIDES AN ISOLATED 24 VDC AT 30 MA DC LOOP POWER OUTPUT AS STANDARD.

THE SCT 502 OFFERS 600 VAC/1,000 VDC ISOLATION WITH A COMMON MODE REJECTION OF 100 DB AT 60 HZ.

IT DELIVERS STANDARD PROCESS CURRENT OR VOLTAGE SIGNALS ON THE OUTPUT WITH A MAXIMUM OF 10 MV P/P OUTPUT RIPPLE. THIS PROVIDES CONVENIENT INTERFACING OF PROCESS SIGNALS TO A COMPUTER SIGNAL OR OTHER PROCESS INSTRUMENTATION FOR IMPROVED RESOLUTION.

ZERO AND SPAN CONTROLS ARE PROVIDED BY TWO SEPARATE INFINITE RESOLUTION POTENTIOMETERS. RECALIBRATION TO OTHER RANGES IN THE FIELD IS EASY AND CONVENIENT.

### TYPICAL APPLICATIONS

- INTERFACE UNEQUAL OR NON-COMPATIBLE PLANT GROUND SYSTEMS
- INTERFACE NON-COMPATIBLE INSTRUMENTS
- COMPUTER/PROGRAMMABLE CONTROLLER INTERFACE
- ISOLATE INTERFERENCE ON SIGNAL LINES
- IMPEDANCE CONVERSION

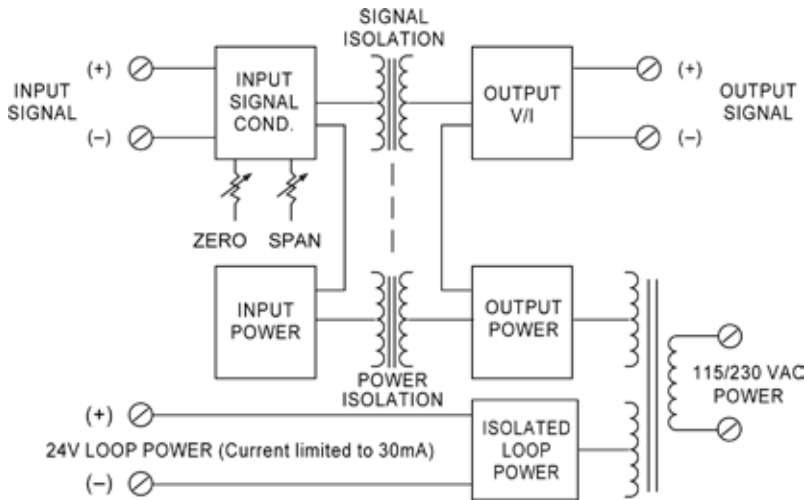

### FEATURES

- DC CURRENT INPUTS: 1 MA TO 20 MA DC (I.E. 4-20 MA DC)
- DC VOLTAGE INPUTS: 100 MV TO 200 VDC (I.E. 1-+5 VDC)
- ZERO-BASED INPUTS: CURRENT & VOLTAGE
- DC PROCESS SIGNAL OUTPUTS: CURRENT AND VOLTAGE
- REPEATABILITY:  $\pm 0.02\%$  OF SPAN TYPICAL
- HIGH ACCURACY:  $\pm 0.1\%$  OF SPAN
- POWER: 115 VAC OR 250 VAC



# CONNECTIONS / DIMENSIONS

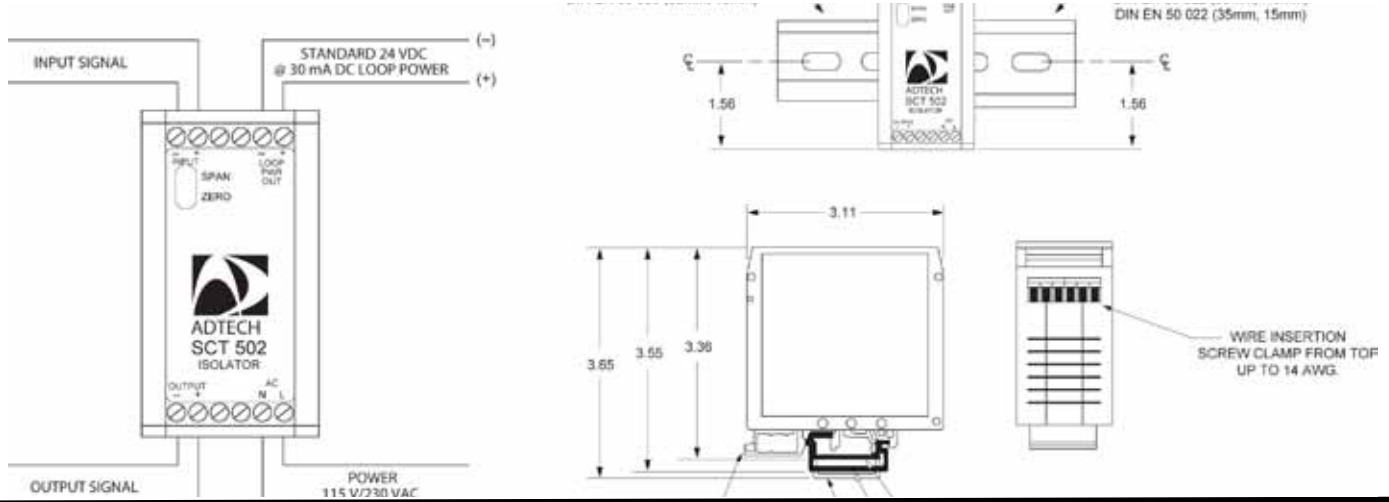

## INPUT/OUTPUT

<p>INPUT SIGNALS: PIN JUMPER CONFIGURABLE</p> <p>4-20 mA DC (Z IN 10 OHMS)</p> <p>0-20 mA DC (Z IN 10 OHMS)</p> <p>1-5 VDC (Z IN 1 MEGOHM)</p> <p>0-5 VDC (Z IN 1 MEGOHM)</p> <p>INPUT SIGNALS: ALTERABLE</p> <p>0-1 mA DC (Z IN 200 OHMS)</p> <p>0-10 VDC (Z IN 1 MEGOHM)</p> <p>ANY ZERO BASED VOLTAGE FROM 100 MV TO 200 VDC.</p>	<p>OUTPUT SIGNALS: PIN JUMPER CONFIGURABLE</p> <p>4-20 mA DC 0-900 OHMS MAX.</p> <p>0-20 mA DC 0-900 OHMS MAX.</p> <p>1-5 VDC 1 MEGOHM MIN.</p> <p>0-5 VDC 1 MEGOHM MIN.</p> <p>OUTPUT SIGNALS: ALTERABLE</p> <p>0-1 mA DC 20K OHMS MAX.</p> <p>0-10 VDC 1 MEGOHM MIN.</p>
--	--

## PERFORMANCE

<p>CALIBRATED ACCURACY: <math>\pm 0.1\%</math></p> <p>LINEARITY: <math>\pm 0.1\%</math> MAX., <math>\pm 0.04\%</math> TYPICAL</p> <p>REPEATABILITY: <math>\pm 0.05\%</math> MAXIMUM</p> <p>TEMPERATURE STABILITY: <math>\pm 0.01\%</math> / °F MAX., <math>\pm 0.004\%</math> / °F TYPICAL</p> <p>LOAD EFFECT: <math>\pm 0.01\%</math> ZERO TO FULL LOAD</p> <p>OUTPUT RIPPLE: 10MV P/P MAXIMUM</p> <p>RESPONSE TIME: 150 MILLISECONDS</p>	<p>TEMPERATURE RANGE:</p> <p>0° TO 140°F (-18°C TO 60°C) OPERATING;</p> <p>-40° TO 185°F (-40°C TO 85°C) STORAGE</p> <p>POWER SUPPLY EFFECT: <math>\pm 0.05\%</math> FOR <math>\pm 10\%</math> POWER VARIATION</p> <p>COMMON MODE REJECTION: 100DB @ 60HZ.</p> <p>ISOLATION: INPUT/OUTPUT/POWER 600VAC, 50/60 HZ, 1,000 VDC FOR AC POWERED UNITS</p>
--	--

NOTE: ALL ACCURACIES ARE GIVEN AS A PERCENTAGE OF SPAN.

## POWER

115 VAC: 50/60 HZ, 0.7 PF (STANDARD)	230 VAC: 50/60 HZ, 0.7 PF (OPTION P5)
--------------------------------------	---------------------------------------

NOTE: ALL UNITS 3 WATTS MAXIMUM, AND A  $\pm 10\%$  POWER VARIATION UNLESS NOTED. FOR DC POWER, CONSULT THE FACTORY.

## MECHANICAL

ELECTRICAL CLASSIFICATION: GENERAL PURPOSE	MOUNTING: DIN: OPTIONAL NEMA 4
CONNECTION: SCREW COMPRESSION TYPE	WEIGHT: NET UNIT: 9.0 OZ (257 GRAMS)
ACCEPTS UP TO 14 AWG	SHIPPING: 16.0 OZ (455 GRAMS)

CONTROLS: MULTITURN ZERO AND SPAN CONTROLS

## OPTIONS

OPTION NUMBER	DESCRIPTION
I 14	VOLTAGE INPUTS TO 200 VDC, 1 MEGOHM MIN. IMPEDANCE; CURRENT INPUTS OF 100 MA MAX.

**Ordering Information**

- Model number
- Input signal
- Output signal
- Prime power with option no.
- Input/output options
- Housing and miscellaneous options

*Please refer to the Housing and/or Option Section for more specific and detailed information.*