



ADTECH

95 Mt. Read Blvd # 149
Rochester, New York 14611 USA

www.adtech-inst.com

SIGNAL LIMITER MODULE MODEL NO. SLM-62

THE ADTECH MODEL SLM 62 SIGNAL LIMITER MODULE PROVIDES AN ACCURATE AND ECONOMICAL MEANS OF LIMITING THE OUTPUT SIGNAL TO PREDETERMINED LEVELS VIA INDEPENDENT HIGH- AND LOW-LIMIT ADJUSTMENTS. THE SLM 62 CONVERTS A CURRENT OR VOLTAGE INPUT TO A STANDARD PROCESS SIGNAL SUCH AS 4-20 MA DC, 1-5 VDC OR ZERO-BASED OUTPUT.

THE SLM 62 DELIVERS STANDARD PROCESS CURRENT OR VOLTAGE SIGNALS ON THE OUTPUT WITH A MAXIMUM OF 10 mV P/P OUTPUT RIPPLE. IT OFFERS A CONVENIENT WAY OF INTERFACING HIGH OR LOW-END LIMITED SIGNALS TO A COMPUTER SYSTEM OR OTHER PROCESS INSTRUMENTATION FOR IMPROVED RESOLUTION.

RECALIBRATION TO OTHER DESIRED RANGES IS ACCOMPLISH EASILY. IT USES TEMPERATURE-STABLE, LOW-NOISE COMPONENTS FOR EXCELLENT STABILITY AND NOISE IMMUNITY.

THE SLM 62 EMPLOYS THE LATEST DESIGN AND COMPONENTS UTILIZING PROVEN TECHNIQUES FRO SUPERIOR RELIABILITY, ACCURACY AND SERVICEABILITY.

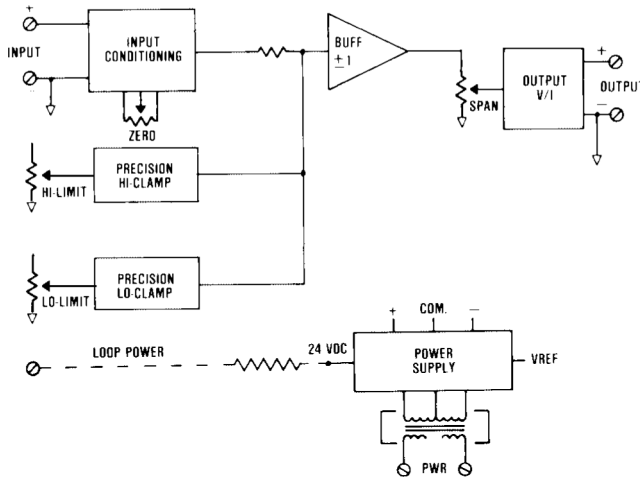

FEATURES

- INDEPENDENT ADJUSTMENTS: HIGH AND LOW LIMITS
- DC CURRENT INPUTS: 4-20 MA, ETC.
- DC VOLTAGE INPUTS: 1-5 VDC, ETC.
- HIGH INPUT IMPEDANCE: 10 MEGOHMS MINIMUM
- ZERO-BASED INPUTS: CURRENT AND VOLTAGE
- DC PROCESS SIGNAL OUTPUTS: CURRENT AND VOLTAGE
- REPEATABILITY: $\pm 0.02\%$ OF SPAN
- HIGH ACCURACY: $\pm 0.1\%$ OF SPAN

TYPICAL APPLICATIONS

- RESTRICT OPERATING RANGE OF OUTPUTS TO PROCESS CONTROL/ACTUATORS
- LIMIT CONTROLLER



CONNECTIONS / DIMENSIONS

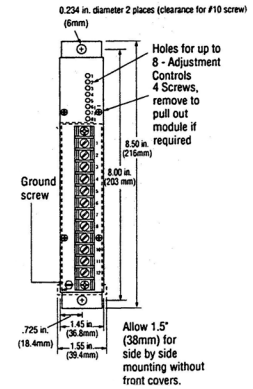
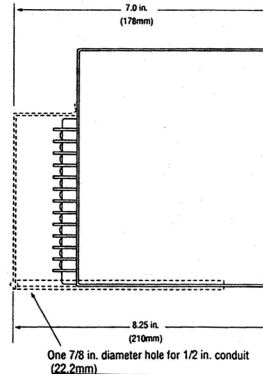
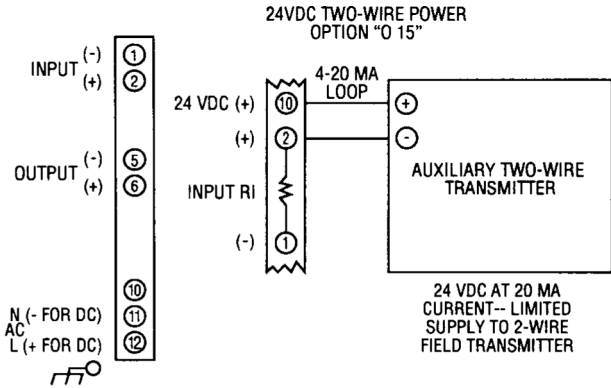

INPUT/OUTPUT

INPUT SIGNALS

4-20 mA DC (Z IN 250 OHMS)
 10-50 mA DC (Z IN 100 OHMS)
 0-1 mA DC (Z IN 5K OHMS)
 0-10 mA DC (Z IN 500 OHMS)
 1-5 VDC (Z IN 10 MEGOHMS)
 0-5 VDC (Z IN 10 MEGOHMS)
 0-10 VDC (Z IN 1 MEGOHM)
 OTHER ZERO-BASED CURRENT AND VOLTAGES ARE AVAILABLE.

OUTPUT SIGNALS/ OUTPUT DRIVE (RL)

SIGNAL	AC POWER (RL)	DC POWER (RL)
4-20 mA DC	0-1,000 OHMS MAX.	0-900 OHMS MAX.
10-50 mA DC	0-400 OHMS MAX.	0-350 OHMS MAX.
0-1 mA DC	0-20,000 OHMS MAX.	0-18,000 OHMS MAX.
1-5 VDC	100K OHMS MIN.	100K OHMS MIN.
0-10 VDC	200K OHMS MIN.	200K OHMS MIN.

PERFORMANCE

CALIBRATED ACCURACY: ±0.1%
LINEARITY: ±0.1% MAXIMUM, ±0.04% TYPICAL
REPEATABILITY: ±0.05% MAXIMUM
TEMPERATURE STABILITY: ±0.01% / °F MAXIMUM, ±0.004% / °F TYPICAL
LOAD EFFECT: ±0.01% ZERO TO FULL LOAD
LIMIT ADJUSTMENT: 0-100% SPAN
OUTPUT RIPPLE: 10 mV P/P MAXIMUM
RESPONSE TIME: 150 MILLISECONDS
TEMPERATURE RANGE: 0° TO 140 °F (-18° TO 60 °C) OPERATING; -40° TO 185 °F (-40° TO 85 °C) STORAGE
POWER SUPPLY EFFECT: ±0.05% FOR A ±10% POWER VARIATION
 NOTE: ALL ACCURACIES ARE GIVEN AS A PERCENTAGE OF SPAN.

POWER

115 VAC: 50/60 HZ, 0.7 PF (STANDARD)	48 VDC: ISOLATED	(OPTION P3)
12 VDC: ISOLATED (OPTION P8)	125 VDC: ISOLATED (105-140 VDC)	(OPTION P4)
24 VDC: NON-ISOLATED (OPTION P1)	230 VAC: 50/60 HZ, 0.7 PF	(OPTION P5)
24 VDC: ISOLATED (OPTION P2)		

NOTE: ALL UNITS 3 WATTS MAXIMUM, AND ±10% POWER VARIATION UNLESS NOTED.

MECHANICAL

ELECTRICAL CLASSIFICATION: GENERAL PURPOSE
CONNECTION: BARRIER TERMINAL STRIP (3/8" SPACING, NO. 6 SCREWS)
CONTROLS: MULTITURN ZERO AND SPAN CONTROLS
MOUNTING: SURFACE MOUNTING STANDARD. SEE HOUSINGS SECTION FOR OPTIONS.
WEIGHT: NET UNIT: 2.6 POUNDS (1.18 KILOGRAMS);
SHIPPING: 3.0 POUNDS (1.36 KILOGRAMS)

OPTIONS

OPTION NUMBER	DESCRIPTION
I 14	VOLTAGE INPUTS TO 200 VDC, 1 MEGOHM MIN. IMPEDANCE; CURRENT INPUTS OF 100 MA MAX.
O 10	BIPOLAR CURRENT (LARGER THAN + 1 MA)
O 11	BIPOLAR VOLTAGE TO ±10 VDC; AT 1 MA, BIPOLAR CURRENT ±1 MA
O 15	TWO-WIRE TRANSMITTER EXCITATION
H 11	WIDE-LINE CONDUIT MOUNTING PLATE AND TERMINAL COVER
H 13B, H 14B, H 15B	NEMA 4, 7, AND 12 ENCLOSURES

Ordering Information

- Model number
- Input signal
- Output signal
- High- and low-limit output
- Prime power with option no.
- Input/output options
- Housing and miscellaneous options

Please refer to the Housing and/or Option Section for more specific and detailed information.