



ADTECH

95 Mt. Read Blvd # 149
Rochester, New York 14611 USA
Phone: 1.585.698.0445
Fax: 1.585.697.0445

www.adtech-inst.com

ADJUSTABLE RAMP BUFFER MODEL NO. ARB 96

THE ADTECH MODEL ARB 96 ADJUSTABLE RAMP BUFFER PROVIDES AN ACCURATE AND ECONOMICAL MEANS OF LIMITING/CONTROLLING THE RATE OF CHANGE OF AN INPUT PROCESS SIGNAL SUCH AS 4-20 MA DC.

IF THE RATE OF CHANGE EXCEEDS THE PRESET HIGH OR LOW LIMIT, THE OUTPUT GOES INTO THE RAMP MODE AT THE PRESET RATE. AS LONG AS THE RATE OF CHANGE IS BELOW THE PRESET LIMIT, THE OUTPUT FOLLOWS THE INPUT.

UPRATE AND DOWNRATE ARE INDEPENDENTLY ADJUSTABLE BY TWO INFINITE RESOLUTION POTENTIOMETERS IN FRONT OF THE INSTRUMENT. OPTIONALLY, A RATE LIMIT ALARM RELAY OUTPUT MAY BE ORDERED.

AN EXTERNAL CONTACT INPUT ALLOWS THE OUTPUT TO BE INSTANTANEOUSLY RESET TO ZERO PERCENT OF RANGE FOR THE DURATION OF THE CONTACT COMMAND AS A STANDARD FEATURE AND MAY BE USED TO INITIATE A SOAK CYCLE, OR INTERFACE A RELAY TO A MODULATING VALVE.

THE ARB 96 PROVIDES STANDARD PROCESS CURRENT OR VOLTAGE SIGNALS ON THE OUTPUT WITH A MAXIMUM OF 10 mV P/P OUTPUT RIPPLE.

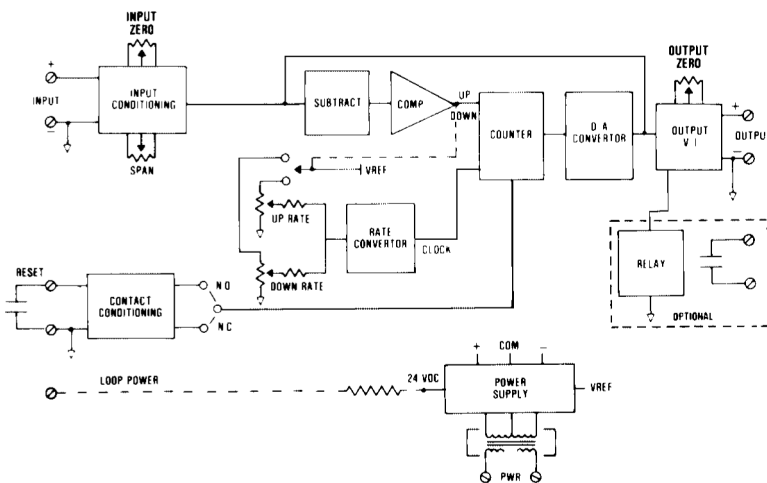

FEATURES

- RATE LIMIT RANGE: 0.1 SEC. TO 50 DAYS
- DC CURRENT INPUTS: 4-20 MA, ETC
- DC VOLTAGE INPUTS
- HIGH-INPUT IMPEDENCE: 10 MEGOHMS MINIMUM
- ZERO-BASED INPUTS: CURRENT AND VOLTAGE
- DC PROCESS SIGNAL OUTPUTS: CURRENT AND VOLTAGE
- REPEATABILITY: $\pm 0.02\%$ OF SPAN
- HIGH ACCURACY: $\pm 0.1\%$ OF SPAN

TYPICAL APPLICATIONS

- RATE-OF-CHANGE ALARM OR RELAY
- SOFT START/ SHUTDOWN
- FURNACE HEAT UP OR COOL DOWN; RATE OF TEMPERATURE CHANGE LIMITING (THERMAL SHOCK LIMITING)
- RATE-LIMITED TRANSMITTER

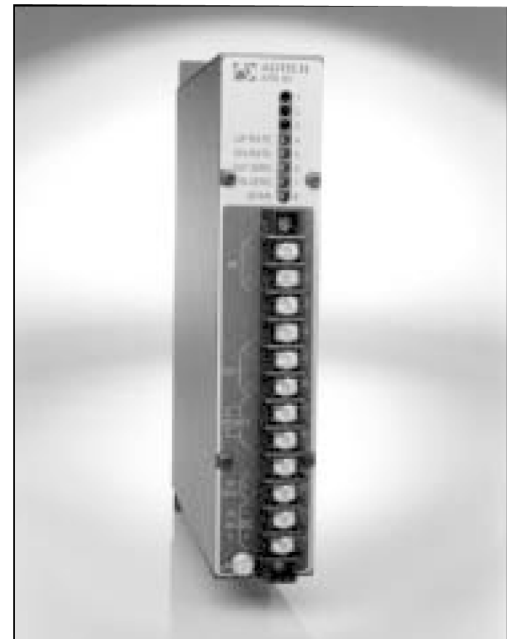

CONNECTIONS / DIMENSIONS

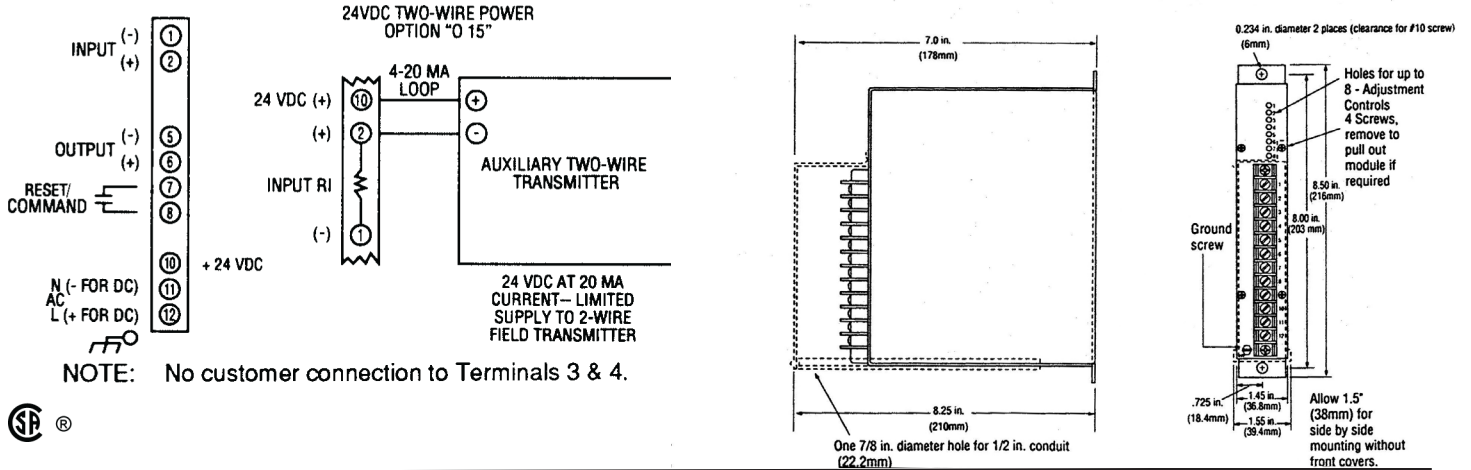

INPUT/OUTPUT

INPUT SIGNALS

4-20 mA DC (Z IN 250 OHMS)
 10-50 mA DC (Z IN 100 OHMS)
 0-1 mA DC (Z IN 5K OHMS)
 0-10 mA DC (Z IN 500 OHMS)
 1-5 VDC (Z IN 10 MEGOHMS)
 0-5 VDC (Z IN 10 MEGOHMS)
 0-10 VDC (Z IN 1 MEGOHM)

OUTPUT SIGNALS / OUTPUT DRIVE (RL)

SIGNAL	AC POWER (RL)	DC POWER (RL)
4-20 mA DC	0-1,000 OHMS MAX.	0-900 OHMS MAX.
10-50 mA DC	0-400 OHMS MAX.	0-350 OHMS MAX.
0-1 mA DC	0-20,000 OHMS MAX.	0-18,000 OHMS MAX.
1-5 VDC	100K OHMS MIN.	100K OHMS MIN.
0-10 VDC	200K OHMS MIN.	200K OHMS MIN.

OTHER ZERO-BASED CURRENT AND VOLTAGES ARE AVAILABLE.

INPUT COMMAND CONTACT: DRY OR SOLID-STATE RATED 24 VDC AT 2 MA
 PULSE: 0-9 TO 0-30 VDC (SPECIFY LOGIC STATE)

PERFORMANCE

CALIBRATED ACCURACY: $\pm 0.1\%$
 LINEARITY: $\pm 0.1\%$ MAX., $\pm 0.04\%$ TYPICAL
 REPEATABILITY: $\pm 0.05\%$ MAXIMUM
 TEMPERATURE STABILITY: $\pm 0.01\%$ / $^{\circ}\text{F}$ MAX.
 $\pm 0.004\%$ / $^{\circ}\text{F}$ TYPICAL
 LOAD EFFECT: $\pm 0.01\%$ ZERO TO FULL LOAD

OUTPUT RIPPLE: 10 mV P/P MAXIMUM
 RESPONSE TIME: DEPENDENT ON RAMP RATE
 TEMPERATURE RANGE: 0° TO 140°F (-18° TO 60°C)
 OPERATING; -40° TO 185°F (-40° TO 85°C) STORAGE
 POWER SUPPLY EFFECT: $\pm 0.05\%$ FOR A
 $\pm 10\%$ POWER VARIATION

NOTE: ALL ACCURACIES ARE GIVEN AS A PERCENTAGE OF SPAN.

POWER

115 VAC: 50/60 HZ, 0.7 PF	(STANDARD)	48 VDC: ISOLATED	(OPTION P3)
12 VDC: ISOLATED	(OPTION P8)	125 VDC: ISOLATED (105-140 VDC)	(OPTION P4)
24 VDC: NON-ISOLATED	(OPTION P1)	230 VAC: 50/60 HZ, 0.7 PF	(OPTION 5)
24 VDC: ISOLATED	(OPTION P2)		

NOTE: ALL UNITS 3 WATTS MAXIMUM, AND A $\pm 10\%$ POWER VARIATION UNLESS NOTED.

MECHANICAL

ELECTRICAL CLASSIFICATION: GENERAL PURPOSE
 CONNECTION: BARRIER TERMINAL STRIP (3/8" SPACING, NO.6 SCREWS)
 CONTROLS: MULTITURN INPUT ZERO, SPAN, OUTPUT ZERO, AND UP AND DOWN RATE CONTROLS
 MOUNTING: SURFACE MOUNTING STANDARD. SEE HOUSINGS SECTION FOR OPTIONS.
 WEIGHT: NET UNIT: 2.6 POUNDS (1.18 KILOGRAMS); SHIPPING: 3.0 POUNDS (1.36 KILOGRAMS)

OPTIONS

OPTION NUMBER	DESCRIPTION
I 14	VOLTAGE INPUTS TO 200 VDC, 1 MEGOHM MIN. IMPEDANCE; CURRENT INPUTS OF 100 MA MAX.
I 18	LOW IMPEDANCE DC CURRENT INPUTS (1/10 OF STANDARD Z)
O 10	BIPOLAR CURRENT (LARGER THAN ± 1 MA)
O 11	BIPOLAR VOLTAGE TO ± 10 VDC; AT 1 MA, BIPOLAR CURRENT ± 1 MA
O 15	TWO-WIRE TRANSMITTER EXCITATION
H 10	THIN-LINE CONDUIT MOUNTING PLATE AND TERMINAL COVER
H 13B, H 14B, H 15B	NEMA 4, 7, AND 12 ENCLOSURES
H 16	PFA 12 HIGH-DENSITY, PLUG-IN ENCLOSURE

Ordering Information

- Model number
- Input signal
- Up rate and down rate
- Reset N.O. or N.C.
- Output signal
- Prime power with option no.
- Input/output options
- Housing and miscellaneous options

Please refer to the Housing and/or Option Section for more specific and detailed information.

