



ADTECH
 Analog-Digital Technology, Inc.
 95 MT. READ BLVD
 ROCHESTER, NY 14611
 PHONE: 585-698-1845
 EMAIL: INFO@ADTECH-INST.COM

DCA 514

DC Current/Voltage Alarm

Instruction Manual

1.0 INTRODUCTION

These instructions refer to the above models. Supplementary sheets are attached if the unit has special options or features. For detailed specifications, see page 4 or refer to the Data Bulletin. All ADTECH instruments are factory calibrated and supplied with a label detailing the calibration. Adjustments are normally not necessary. A simple calibration check should be performed to verify calibration before installing the instrument per 3.0 below.

2.0 GENERAL DESCRIPTION

The ADTECH Model DCA 514 AC powered single alarm accepts standard process DC current or DC voltage input signals and provides a user configurable SPDT relay contact output.

The basic input range is 1 to 20 mA (i.e., 4-20 mA) or any voltage of 100 mV DC to 0-200 VDC (i.e., 1-5 VDC) the output contacts are rated at 10 amps, 30 VDC, or 250 VAC resistive.

An isolated 24 VDC at 30 mA DC output is provided as standard for a loop two-wire transmitter.

An integral dual color LED provides green indication for normal conditions and red indication on alarm independent of relay coil power.

The alarm is furnished as standard with the relay power fail-safe F.S. (i.e., relay coil energized) regardless of high or low alarm configurations. You may specify the relay to be non-fail-safe N.F.S. (i.e., relay coil de-energized).

The DCA 514 is supplied with adjustable dead band of 1 to 100% of input span and an adjustable time delay of 0-30 seconds is also provided as standard.

3.0 INSTALLATION

The instrument is supplied in a DIN mount general purpose enclosure as standard. NEMA 4 or 7 are optionally available. Installation area/location must agree with the supplied instruments including operating temperature and ambient conditions.

Mounting

Refer to the appropriate outline drawing for mounting and clearance dimensions on page 4.

Electrical Connections

The wire used to connect the instrument to the control system **Input/Output** should be a twisted pair(s) and sized according to normal practice. Shielded cable is not normally necessary (if used, the shield must be grounded at the input negative of the ADTECH instrument and left floating at the sensor).

A 12 position compression terminal block is provided for I/O and power connection. A housing ground terminal is not required due to non-metallic housing.

Controls

Multiturn set point (SP) control is provided to set the trip point level on all units. Adjustable deadband (DB) control and adjustable time delay (TD) controls are also provided as standard.

The multiturn control(s) are accessible through the instrument front panel and are clearly marked for ease of use.

Pin jumpers are provided to select the input, the trip mode and relay action per tables on page 3.

4.0 MAINTENANCE

These instruments are electronic except for the relay(s) output(s) and require no maintenance except for periodic cleaning and calibration verification. The standard relay is rated by the manufacturer for 100,000 10 amp operations at 30 vdc or 250 vac and 5 X 10⁶ mechanical operations. Relay output(s) should be verified at user established time intervals. If the unit appears to be mis-operating it should be checked in place per section 6.0 or removed for a bench check per sections 6.0 and 7.0. MOST problems are traced to field wiring and/or associated circuits. If the problem appears to be within the instrument, proceed to section 7.0.

5.0 CONNECTIONS

Standard connections are shown below and on the instrument face plate, Data Bulletin or on attached supplementary sheets.

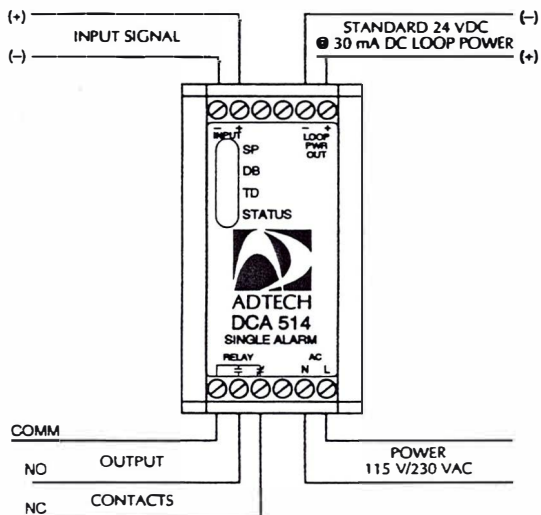

Note: See page 2 for loop power connection to a field transmitter.

6.0 INSTRUMENT SETUP

- A. Using Table 1 select jumpers J2, J3, J4, J5 for the input desired.
- B. Using Table 2 select the alarm type.
- C. Using Table 3 select the relay action.

6.1 CALIBRATION

To perform a calibration check or re-calibration of these alarms follow this procedure.

- A. Make sure the unit I/O wiring is properly connected. The alarm must be at normal input for a minimum of 2 minutes before proceeding to B.
- B. The input signal source must be adjustable from 0-100% in steps of 10% or at least 25%. The source should either be precalibrated or an accurate meter must be used to monitor the input.
- C. The output contacts may be monitored with an ohmmeter or a suitable source with indicator lights to prove contact transfer and LED action.
- D. Set the input source to the value desired for a trip.
- E. Adjust the potentiometer marked Time Delay, "TD" fully counterclockwise for 0 second time delay.
- F. Adjust the potentiometer marked Deadband, "DB" fully counterclockwise to the minimal Deadband (approximately 1% of input span).
- G. Adjust the set point "SP" multiturn potentiometer until the relay operates. The LED will come on when the relay actuates.
- H. Vary the adjustment CW and CCW to get as close as possible to the actual trip point as set in Step D.
- I. Vary the input source to verify that the relay operates at the desired trip point. The DIFFERENCE between the trip setpoint that activates the relay and when it drops out is the amount of deadband.
- J. Adjust the deadband "DB" multiturn potentiometer and vary the input source between pull in/drop out until the desired deadband is obtained.
- K. The deadband adjustment has a minimal effect on the trip point. For improved accuracy/resolution, check and adjust (if needed) the SP control as described in Steps D, E, F and G.
- L. Adjust the potentiometer marked Time Delay, "TD" to set the desired time delay 0-30 sec. The time delay pot does not affect the Set Point or Dead Band. Also, the delay is only present from input changing from no alarm to alarm condition. Once in the alarm state, the time delay has no effect on the return to the normal or no alarm state
- M. This completes the calibration.

NOTE:

If recalibration to a different relay action is required, proceed to the tables listed under Section 8.0.

7.0 FIELD TROUBLE SHOOTING GUIDE

This section offers a simple, first level trouble-shooting aid for an apparent instrument malfunction.

SYMPTOM	CORRECTIVE ACTION
No output	<ol style="list-style-type: none"> 1. Check the input and output connections carefully. 2. Check that the input signal polarity is correct and that it is present on the instrument terminals. 3. Check that the input source(s) is correct and that it changes magnitude between zero and full scale values when so adjusted. <p>All external checks are complete. Problem seems to be internal.</p>

If the problem seems to be internal, replace the instrument with a spare and return the defective instrument to ADTECH for prompt check out and repair. To avoid unnecessary delays always send a cover note with the name and telephone number of the contact and return address. Along with a brief description of what the unit is doing when it fails.

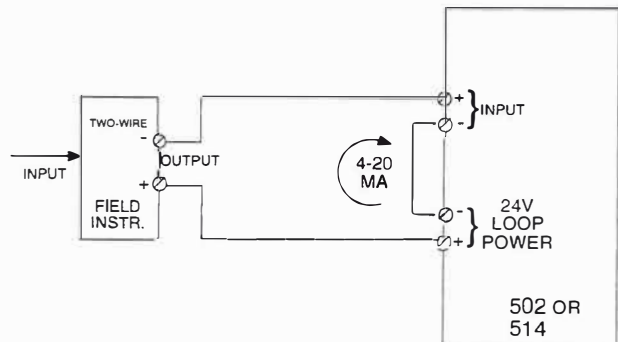

24V-LOOP POWER CONNECTION TO FIELD TRANSMITTER

8.0 TABLES, PCB LAYOUT

TABLE 1

INPUT	JUMPER			
	J2	J3	J4	J5
0 – 1 mA	B	A	A	B
0 – 10 mA	A	B	A	B
0 – 20 mA	A	B	A	A
4 – 20 mA	A	B	A	A
0 – 100 mV	B	B	A	B
0 – 200 mV	B	B	A	A
0 – 5 V	B	B	B	A
1 – 5 V	B	B	B	A
0 – 10 V	B	B	B	–

TABLE 2

ALARM TYPE	J6
LOW	B
HIGH	A

TABLE 3

RELAY ACTION	J1
FAIL SAFE (FS)	B
NON FAIL SAFE (NFS)	A

Note: FS means relay-coil normally energized.

TABLE 4

115V	J1, J2 IN; J3 OUT
230 V	J3 IN; J1, J2 OUT

Jumpers on power supply PCB

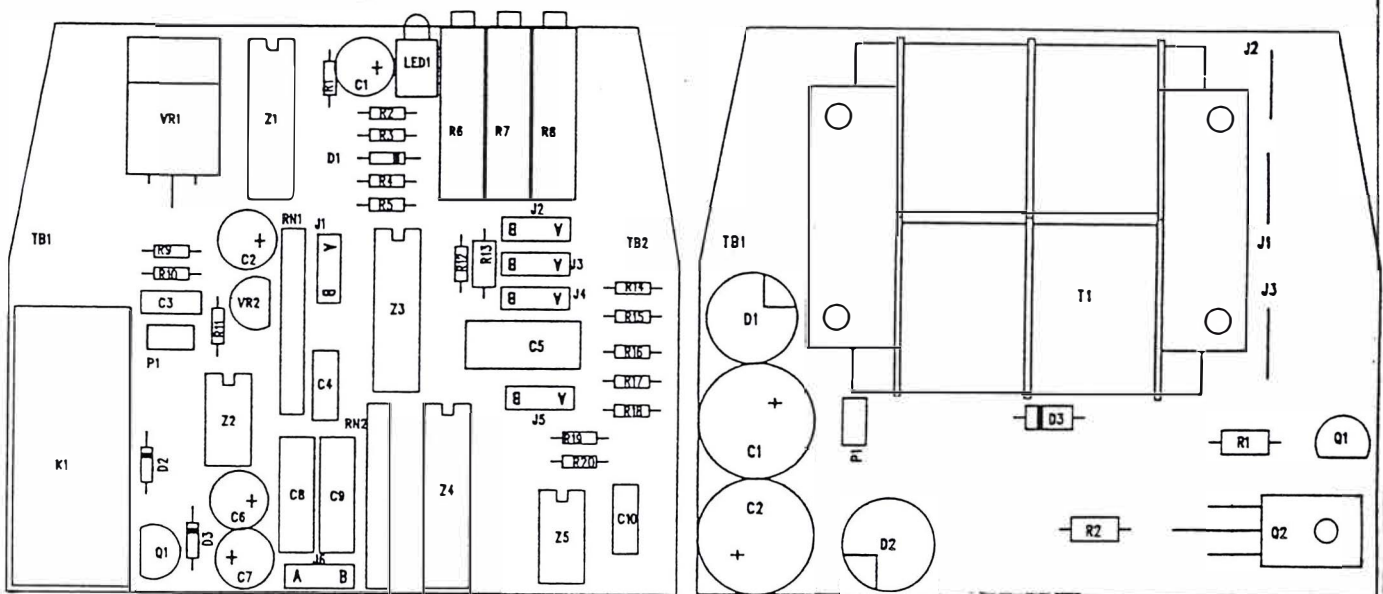

9.0 SPECIFICATIONS

INPUT/OUTPUT

INPUT SIGNAL

Pin Jumper Configurable

- a. 0-1 mA DC (Z in 100 ohms)
- b. 0-10 mA DC (Z in 10 ohms)
- c. 0-20 mA (Z in 10 ohms)
- d. 4-20 mA (Z in 10 ohms)
- e. 0-100 mV DC (Z in 1 megohm)
- f. 0-200 mV DC (Z in 1 megohm)
- g. 0-5 VDC (Z in 1 megohm)
- h. 1-5 VDC (Z in 1 megohm)
- i. 0-10 VDC (Z in 1 megohm)

Alterable

- a. Any zero based voltage from 200 MV to 200 VDC.

- e. **Adjustable Time Delay:** 0-30 seconds
- f. **Power Supply Effect:** $\pm 0.05\%$ for a $\pm 10\%$ power variation
- g. **Isolation:** Input/output/power 1,500 VAC, 50/60 Hz, for AC & powered units.
- h. **Response Time:** less than 200 milliseconds
- i. **Temperature Range:** 0° to 140°F (-18° to 60°C) operating
-40° to 185°F (-40° to 85°C) storage

Note: All accuracies are given as a percentage of span

POWER

- a. **115 VAC:** 50/60 Hz, 0.7 PF (Standard)
- b. **230 VAC:** 50/60 Hz, 0.7 PF (Option P5)

Note: All units 3 watts maximum, and a $\pm 10\%$ power variation unless noted. For DC power, consult factory.

OUTPUT SIGNALS

Standard

- a. SPDT contact rated 10 amps at 30 VDC or 250 VAC resistive.
- b. Isolated 24 VDC at 30 mA DC two-wire transmitter excitation

Note: Pin jumper configurable Alarm type-high or low Relay Action F.S. or N.F.S.

PERFORMANCE

- a. **Repeatability:** $\pm 0.1\%$ of span
- b. **Trip Point Stability:** $\pm 0.004\%/^{\circ}\text{F}$ typical
 $\pm 0.01\%/^{\circ}\text{F}$ maximum for a 50°F change from ambient
- c. **Trip Adjustment:** 0-100% of span continuously adjustable
Blind set: infinite resolution
- d. **Adjustable Dead Band:** 1-100% of span continuously adjustable
Blind Set: infinite resolution

MECHANICAL

- a. **Electrical Classification:** General purpose
- b. **Connection:** Screw compression type accepts up to 14 AWG
- c. **Controls:** Multiturn trip set, dead band and time delay controls.
- d. **Mounting:** DIN: Optional Nema 4
- e. **Weight:** Net unit: 9.0 oz. (257 grams)
Shipping: 16.0 oz. (455 grams)

OPTIONS

Option No.	Description
I 14	Voltage inputs to 200 VDC, 1 megohm min. impedance; current inputs of 100 mA max.

10.0 OUTLINE AND MOUNTING

