



ADTECH

95 Mt. Read Blvd # 149
Rochester, New York 14611 USA
Phone: 1.585.698.1845
Fax: 1.585.697.0445

www.adtech-inst.com

NON-ISOLATED POTENTIOMETER TRANSMITTER MODEL NO. PTT 73

THE ADTECH MODEL PTT 73 POTENTIOMETER TRANSMITTER PROVIDES ACCURATE CONVERSION OF POTENTIOMETER SIGNALS TO A STANDARD PROCESS SIGNAL SUCH AS 4-20 MA DC, 1-5 VDC, OR ZERO-BASED OUTPUTS.

THE PTT 73 PROVIDES CONSTANT CURRENT EXCITATION TO THE POTENTIOMETERS SO THAT CALIBRATION IS NOT AFFECTED BY LEAD LENGTH AND LEAD TEMPERATURE CHANGES.

AN IMPORTANT STANDARD FEATURE IS ITS ABILITY TO PROVIDE ELEVATED RANGES (I.E. ON A 0 OHM TO 1,000 OHM POTENTIOMETER). THE UNIT MAY BE ORDERED FOR A 400 OHM TO 800 OHM INPUT RANGE TO PROVIDE A FULL-SCALE OUTPUT SUCH AS 4-20 MA DC.

THE PTT 73 PROVIDES STANDARD PROCESS CURRENT OR VOLTAGE SIGNALS ON THE OUTPUT WITH A MAXIMUM OF 10 MV P/P OUTPUT RIPPLE. IT ALLOWS ANY COMPUTER OR COMPUTER-TYPE SYSTEM TO HAVE IMPROVED MEASUREMENT RESOLUTION.

IT USES STATE-OF-THE-ART DESIGN TECHNIQUES AND COMPONENTS FOR THE UTMOST IN RELIABILITY, ACCURACY, AND SERVICEABILITY.

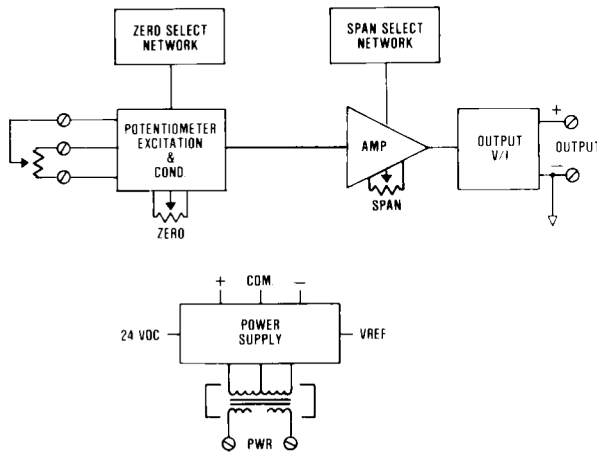

TYPICAL APPLICATIONS

- LEVEL MEASUREMENT
- MECHANICAL POSITION MEASUREMENT
- RECORDER SLIDE-WIRE POSITION MEASUREMENT
- MANUAL INPUT STATION

FEATURES

- DIRECT POTENTIOMETER INPUTS
- SELECTABLE RANGES: 0 TO 2, 0 TO 13.33, 1 TO 5, AND 3-12 SECONDS ARE TYPICAL INPUT RANGES
- RESPONSE TIME: 1 PERIOD
- DIGITAL ACCURACY: ± 1 PART IN 40%
- INDICATION: FOR OUT-OF-RANGE OR LOSS-OF-INPUT
- DC PROCESS SIGNAL OUTPUTS: CURRENT AND VOLTAGE
- REPEATABILITY: $\pm 0.02\%$ OF SPAN
- HIGH ACCURACY: $\pm 0.1\%$ OF SPAN



CONNECTIONS / DIMENSIONS

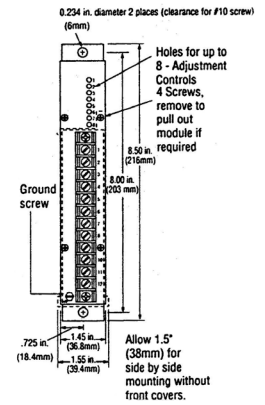
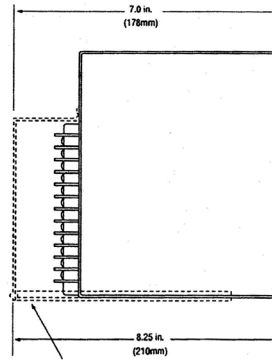
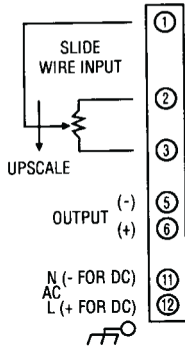

One 7/8 in. diameter hole for 1/2 in. conduit (22.2mm)

INPUT/OUTPUT

INPUT SIGNALS
 POTENTIOMETER / SLIDE-WIRE
 SENSOR: 2 - OR 3-WIRE
 10 TO 10,000 OHMS RESISTANCE
 SPANS: STANDARD
 HIGHER AND LOWER RANGES:
 OPTIONAL

OUTPUT SIGNALS / OUTPUT DRIVE (RL)

SIGNAL	AC POWER (RL)	DC POWER (RL)
4-20 mA DC	0-1,000 OHMS MAX.	0-900 OHMS MAX.
10-50 mA DC	0-400 OHMS MAX.	0-350 OHMS MAX.
0-1 mA DC	0-20,000 OHMS MAX.	0-18,000 OHMS MAX.
1-5 VDC	100K OHMS MIN.	100K OHMS MIN.
0-10 VDC	200K OHMS MIN.	

PERFORMANCE

CALIBRATED ACCURACY: $\pm 0.1\%$
 LINEARITY: $\pm 0.1\%$ MAX., $\pm 0.04\%$ TYPICAL
 REPEATABILITY: $\pm 0.05\%$ MAXIMUM
 TEMPERATURE STABILITY: $\pm 0.01\%$ / °F
 $\pm 0.004\%$ / °F TYPICAL
 LOAD EFFECT: $\pm 0.01\%$ ZERO TO FULL LOAD

OUTPUT RIPPLE: 10 mV P/P MAXIMUM
 RESPONSE TIME: 150 MILLISECONDS
 TEMPERATURE RANGE: 0° TO 140 °F (-18° TO 60°C)
 OPERATING: -40° TO 185°F (-40° TO 85°C) STORAGE
 POWER SUPPLY EFFECT: $\pm 0.05\%$ FOR A
 $\pm 10\%$ POWER VARIATION

NOTE: ALL ACCURACIES ARE GIVEN AS A PERCENTAGE OF SPAN.

POWER

115 VAC: 50/60 HZ, 0.7 PF	(STANDARD)
12 VDC: ISOLATED	(OPTION P8)
24 VDC: NON-ISOLATED	(OPTION P1)
24 VDC: ISOLATED	(OPTION P2)
48 VDC: ISOLATED	(OPTION P3)
125 VDC: ISOLATED (105-140 VDC)	(OPTION P4)
230 VAC: 50/60 HZ, 0.7 PF	(OPTION P5)

NOTE: ALL UNITS 3 WATTS MAXIMUM, AND $\pm 10\%$ POWER VARIATION UNLESS NOTED

MECHANICAL

ELECTRICAL CLASSIFICATION: GENERAL PURPOSE
 CONNECTION: BARRIER TERMINAL STRIP (3/8" SPACING, NO.6 SCREWS)
 CONTROLS: MULTITURN ZERO AND SPAN CONTROLS
 MOUNTING: SURFACE MOUNTING STANDARD. SEE HOUSINGS SECTION FOR OPTIONS.
 WEIGHT: NET UNIT: 2.6 POUNDS (1.18 KILOGRAMS); SHIPPING: 3.0 POUNDS (1.36 KILOGRAMS)

OPTIONS

OPTION NUMBER	DESCRIPTION
O 10	BIPOLAR CURRENT OUTPUT (LARGER THAN ± 1 MA)
O 11	BIPOLAR VOLTAGE OUTPUT TO ± 10 VDC: AT 1 MA, BIPOLAR CURRENT ± 1 MA
H 10	THIN-LINE CONDUIT MOUNTING PLATE AND TERMINAL COVER
H 13B, H 14B, H 15B	NEMA 4, 7, & 12 ENCLOSURES
H 16	PFA 12 HIGH-DENSITY, PLUG-IN ENCLOSURE

Ordering Information

- Model number
- Input total resistance of potentiometer; percent of potentiometer for zero and span
- Output signal
- Prime power with option no.
- Input/output options
- Housing and miscellaneous options

Please refer to the Housing and/or Option Section for more specific and detailed information.